

CSCI 446: Artificial Intelligence

Constraint Satisfaction Problems II

Instructor: Michele Van Dyne



Today

- Efficient Solution of CSPs
- Local Search



Reminder: CSPs

- CSPs:

- Variables
- Domains
- Constraints
 - Implicit (provide code to compute)
 - Explicit (provide a list of the legal tuples)
 - Unary / Binary / N-ary

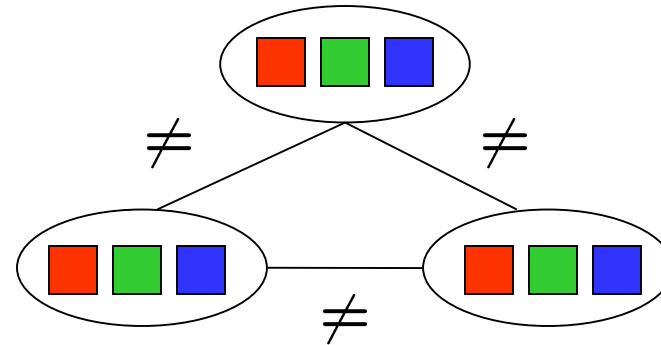

- Goals:

- Here: find any solution
- Also: find all, find best, etc.

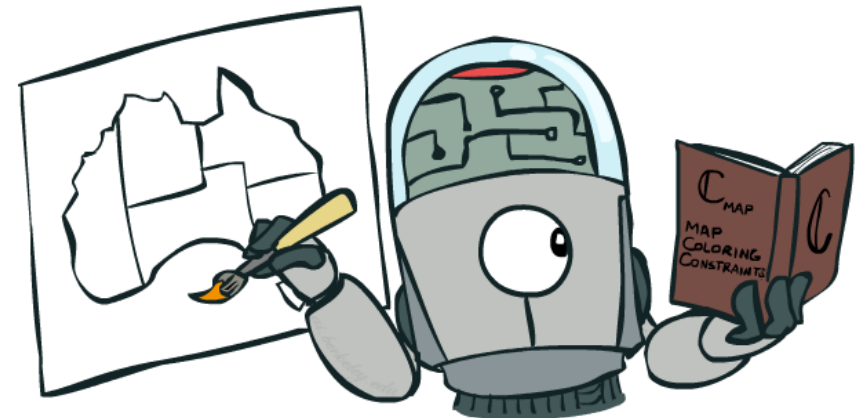

Backtracking Search

```
function BACKTRACKING-SEARCH(csp) returns solution/failure
  return RECURSIVE-BACKTRACKING({ }, csp)

function RECURSIVE-BACKTRACKING(assignment, csp) returns soln/failure
  if assignment is complete then return assignment
  var ← SELECT-UNASSIGNED-VARIABLE(VARIABLES[csp], assignment, csp)
  for each value in ORDER-DOMAIN-VALUES(var, assignment, csp) do
    if value is consistent with assignment given CONSTRAINTS[csp] then
      add {var = value} to assignment
      result ← RECURSIVE-BACKTRACKING(assignment, csp)
      if result ≠ failure then return result
      remove {var = value} from assignment
  return failure
```

Improving Backtracking

- General-purpose ideas give huge gains in speed
 - ... but it's all still NP-hard
- Filtering: Can we detect inevitable failure early?
- Ordering:
 - Which variable should be assigned next? (MRV)
 - In what order should its values be tried? (LCV)
- Structure: Can we exploit the problem structure?



Arc Consistency and Beyond

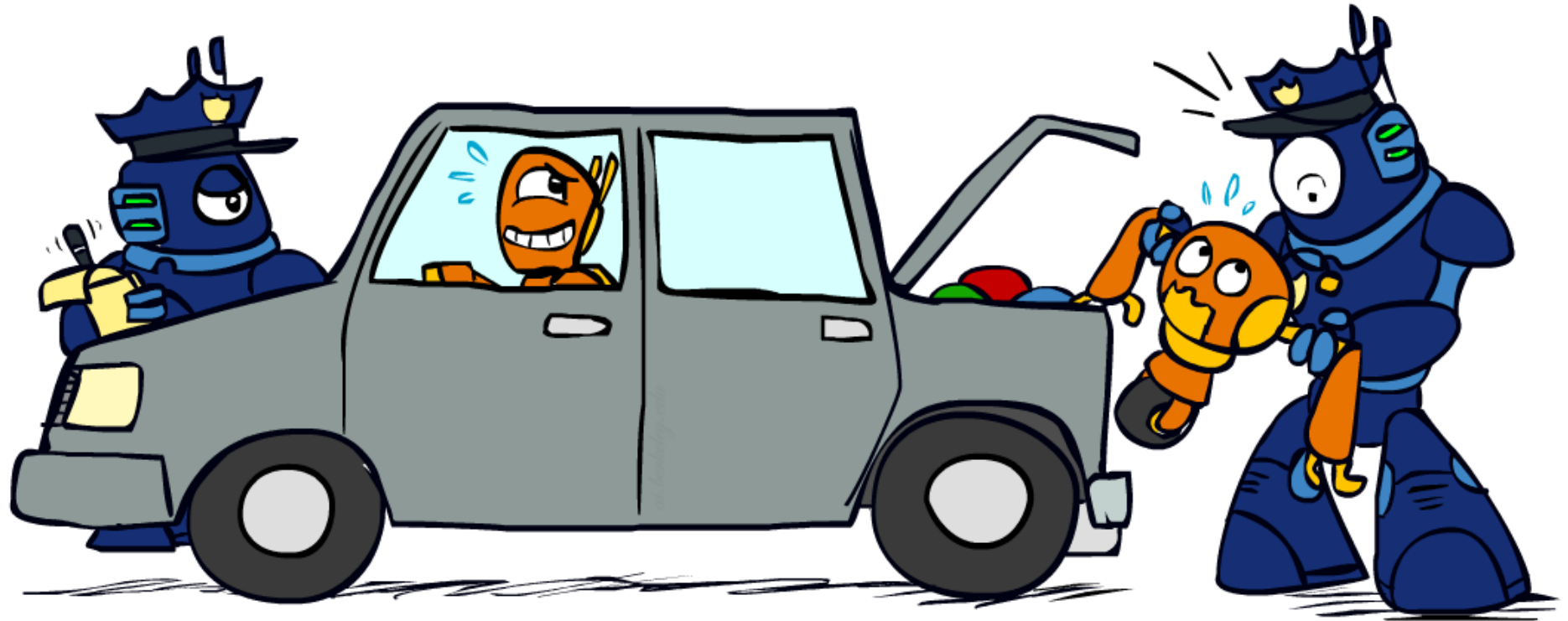

Arc Consistency of an Entire CSP

- A simple form of propagation makes sure **all** arcs are simultaneously consistent:

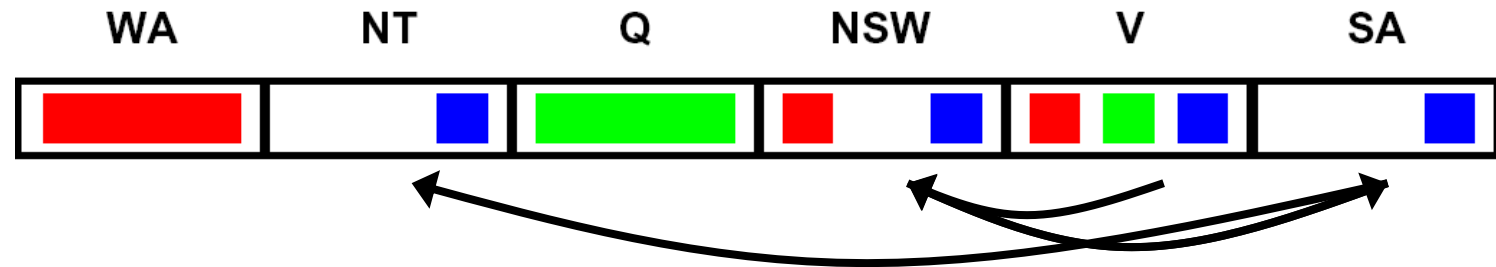
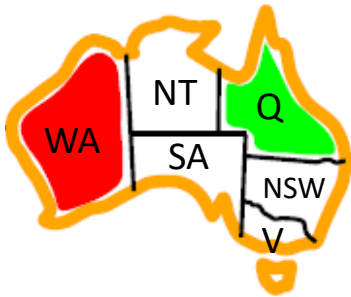

- Arc consistency detects failure earlier than forward checking
- Important: If X loses a value, neighbors of X need to be rechecked!
- Must rerun after each assignment!

Remember: Delete from the tail!

Limitations of Arc Consistency

- After enforcing arc consistency:
 - Can have one solution left
 - Can have multiple solutions left
 - Can have no solutions left (and not know it)
- Arc consistency still runs inside a backtracking search!

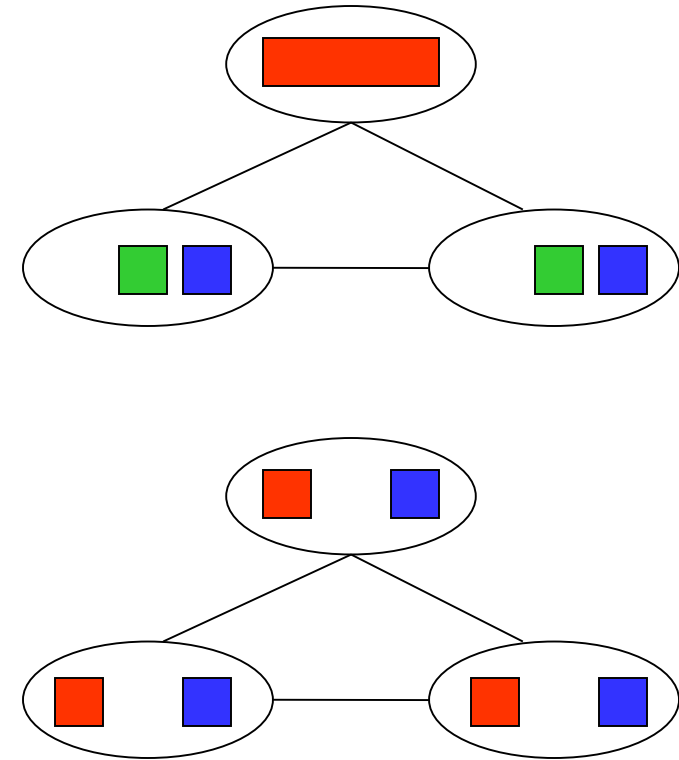

What went wrong here?

K-Consistency

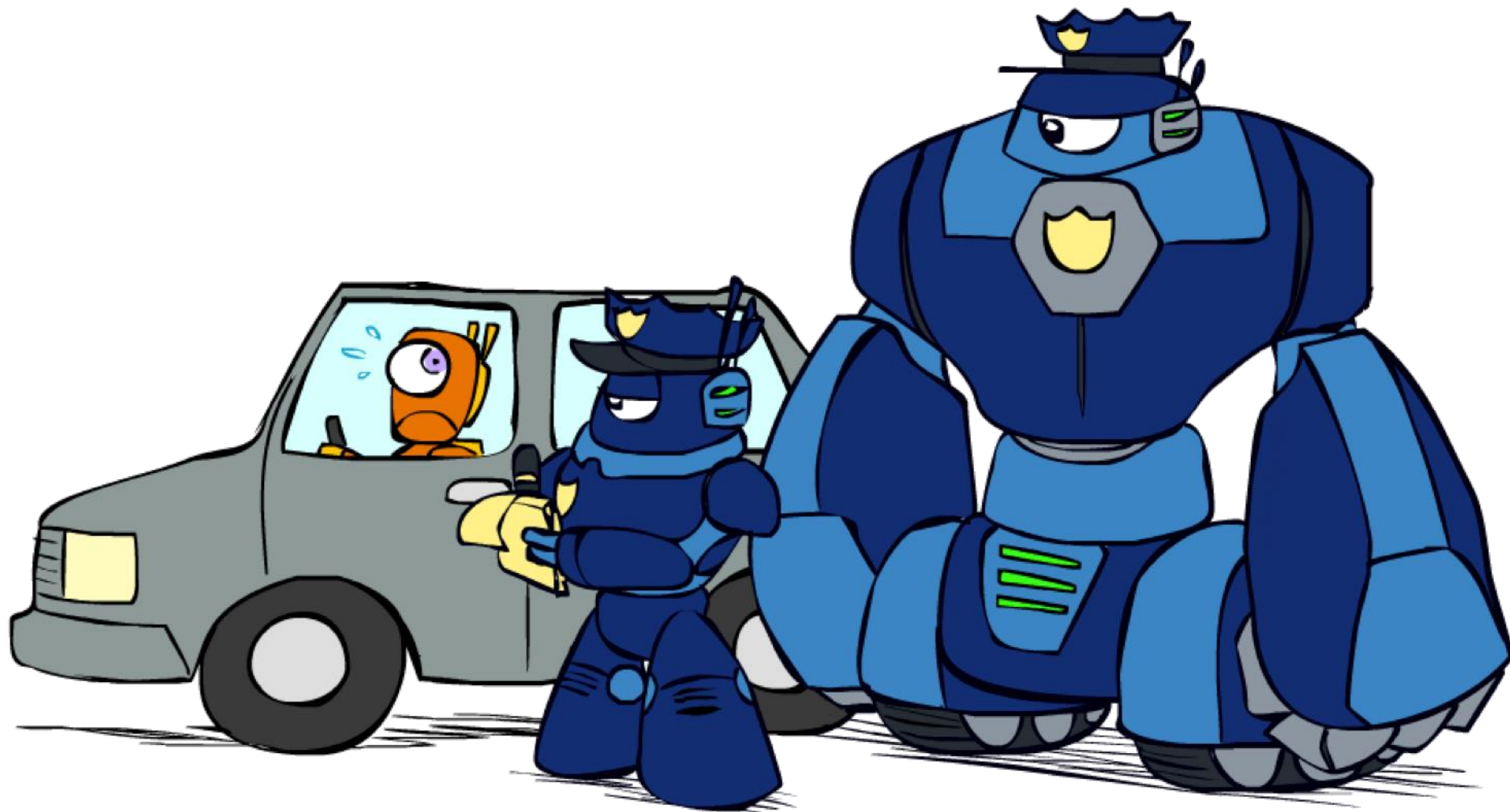

K-Consistency

- Increasing degrees of consistency
 - 1-Consistency (Node Consistency): Each single node's domain has a value which meets that node's unary constraints
 - 2-Consistency (Arc Consistency): For each pair of nodes, any consistent assignment to one can be extended to the other
 - K-Consistency: For each k nodes, any consistent assignment to k-1 can be extended to the kth node.
- Higher k more expensive to compute
- (You need to know the k=2 case: arc consistency)

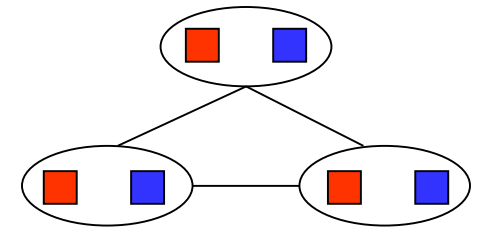
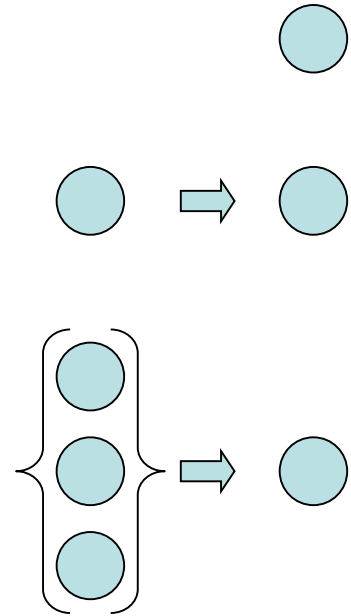

Strong K-Consistency

- Strong k-consistency: also k-1, k-2, ... 1 consistent
- Claim: strong n-consistency means we can solve without backtracking!
- Why?
 - Choose any assignment to any variable
 - Choose a new variable
 - By 2-consistency, there is a choice consistent with the first
 - Choose a new variable
 - By 3-consistency, there is a choice consistent with the first 2
 - ...
- Lots of middle ground between arc consistency and n-consistency! (e.g. k=3, called path consistency)

Structure

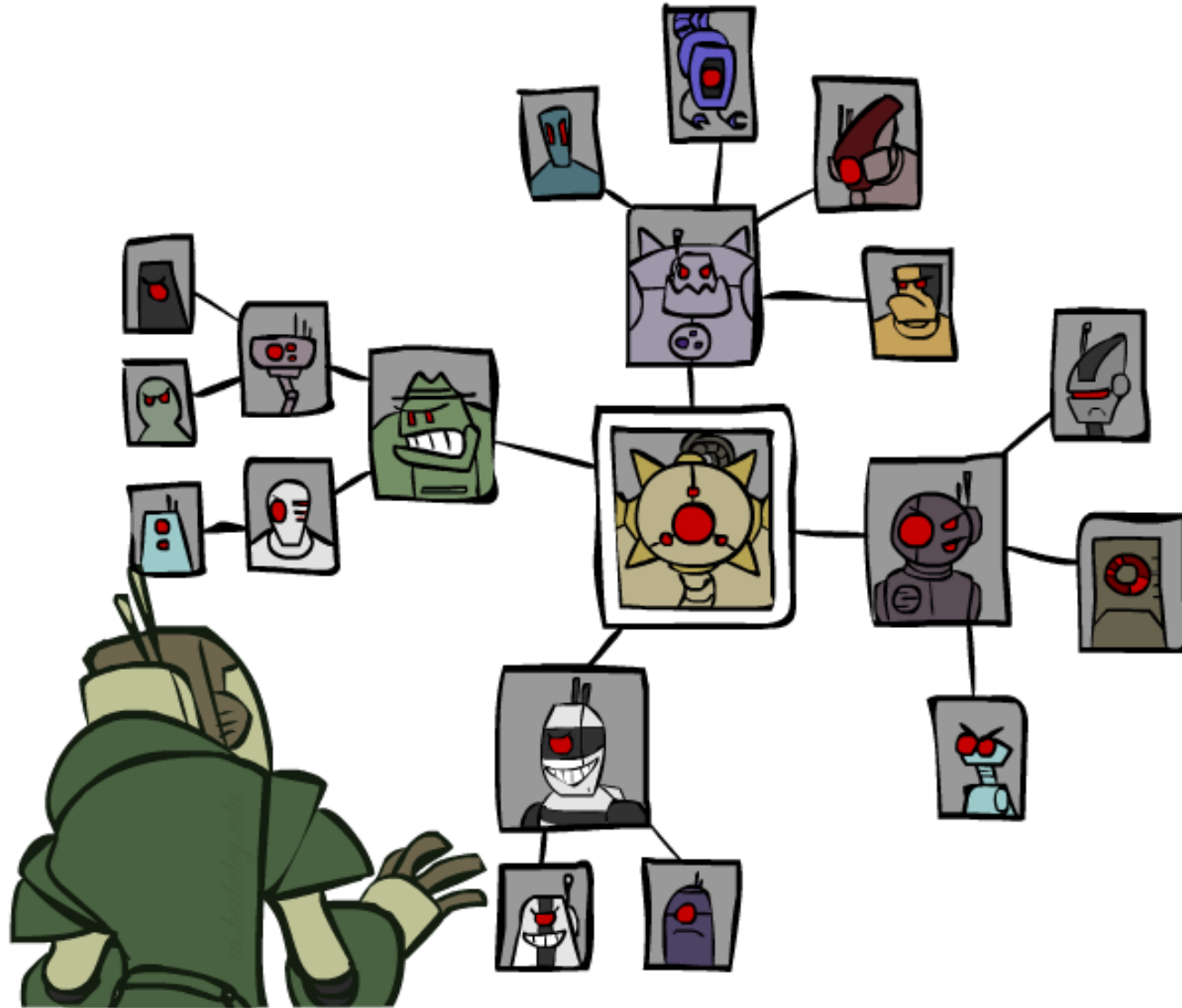

Problem Structure

- Extreme case: independent subproblems
 - Example: Tasmania and mainland do not interact
- Independent subproblems are identifiable as connected components of constraint graph
- Suppose a graph of n variables can be broken into subproblems of only c variables:
 - Worst-case solution cost is $O((n/c)(d^c))$, linear in n
 - E.g., $n = 80$, $d = 2$, $c = 20$
 - $2^{80} = 4$ billion years at 10 million nodes/sec
 - $(4)(2^{20}) = 0.4$ seconds at 10 million nodes/sec

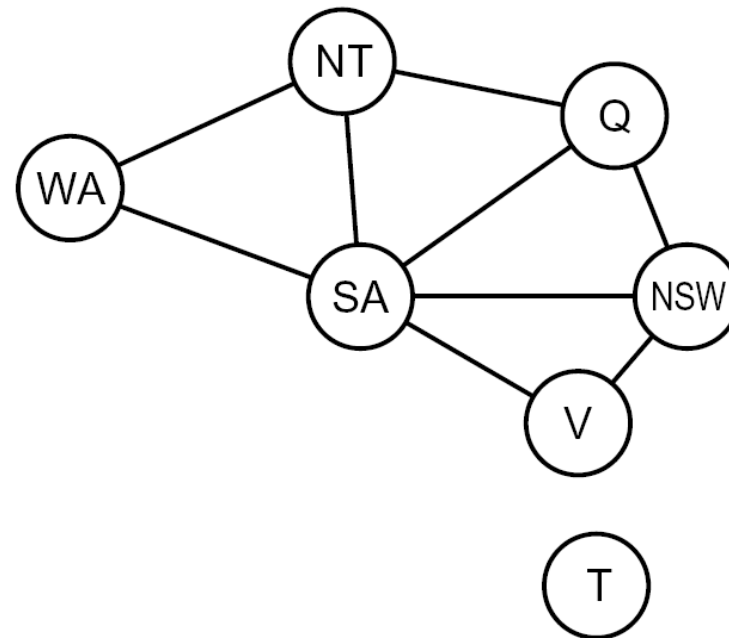

Tree-Structured CSPs

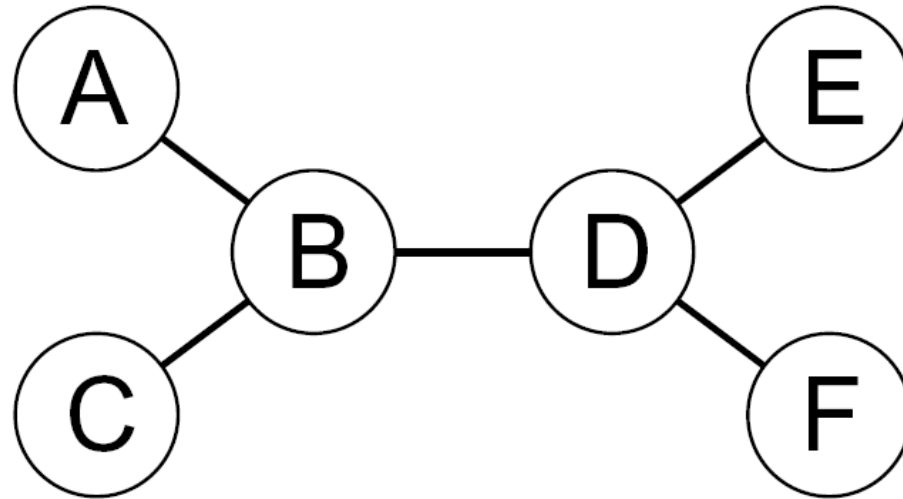

- Theorem: if the constraint graph has no loops, the CSP can be solved in $O(n d^2)$ time
 - Compare to general CSPs, where worst-case time is $O(d^n)$
- This property also applies to probabilistic reasoning (later): an example of the relation between syntactic restrictions and the complexity of reasoning

Tree-Structured CSPs

- Algorithm for tree-structured CSPs:
 - Order: Choose a root variable, order variables so that parents precede children

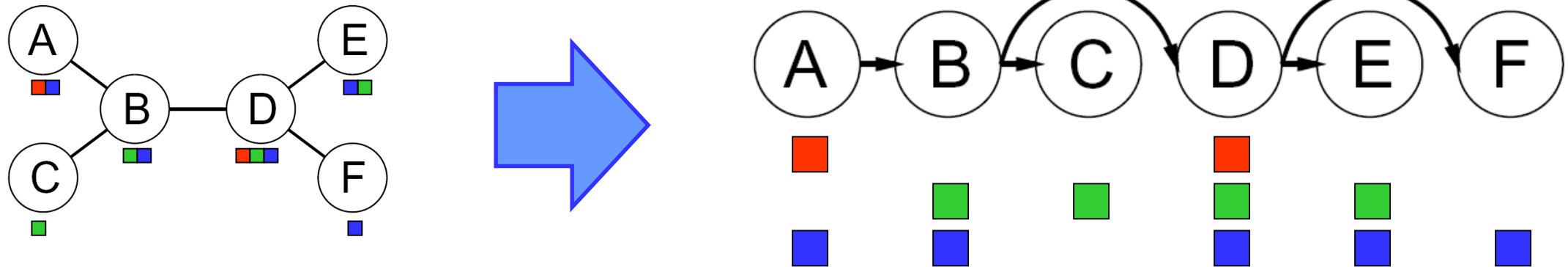

- Remove backward: For $i = n : 2$, apply $\text{RemoveInconsistent}(\text{Parent}(X_i), X_i)$
 - Assign forward: For $i = 1 : n$, assign X_i consistently with $\text{Parent}(X_i)$
- Runtime: $O(n d^2)$ (why?)

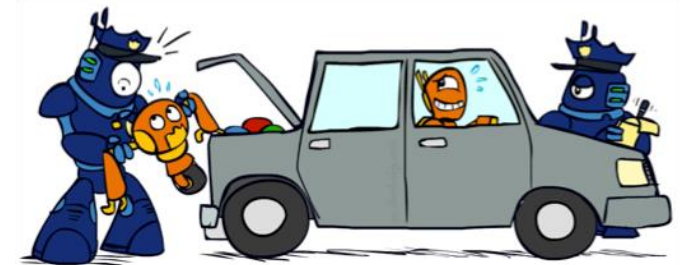

Tree-Structured CSPs

- Claim 1: After backward pass, all root-to-leaf arcs are consistent
- Proof: Each $X \rightarrow Y$ was made consistent at one point and Y 's domain could not have been reduced thereafter (because Y 's children were processed before Y)

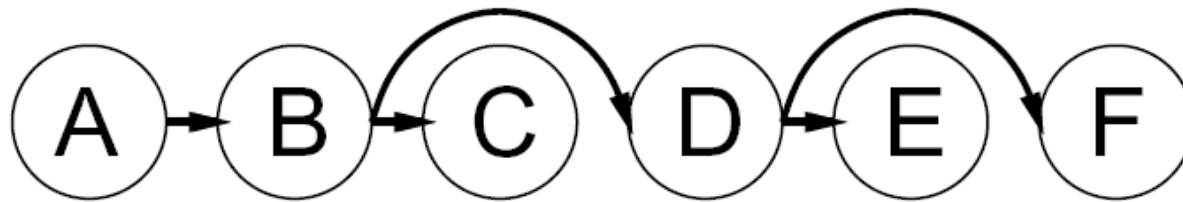

- Claim 2: If root-to-leaf arcs are consistent, forward assignment will not backtrack
- Proof: Induction on position
- Why doesn't this algorithm work with cycles in the constraint graph?
- Note: we'll see this basic idea again with Bayes' nets

Improving Structure

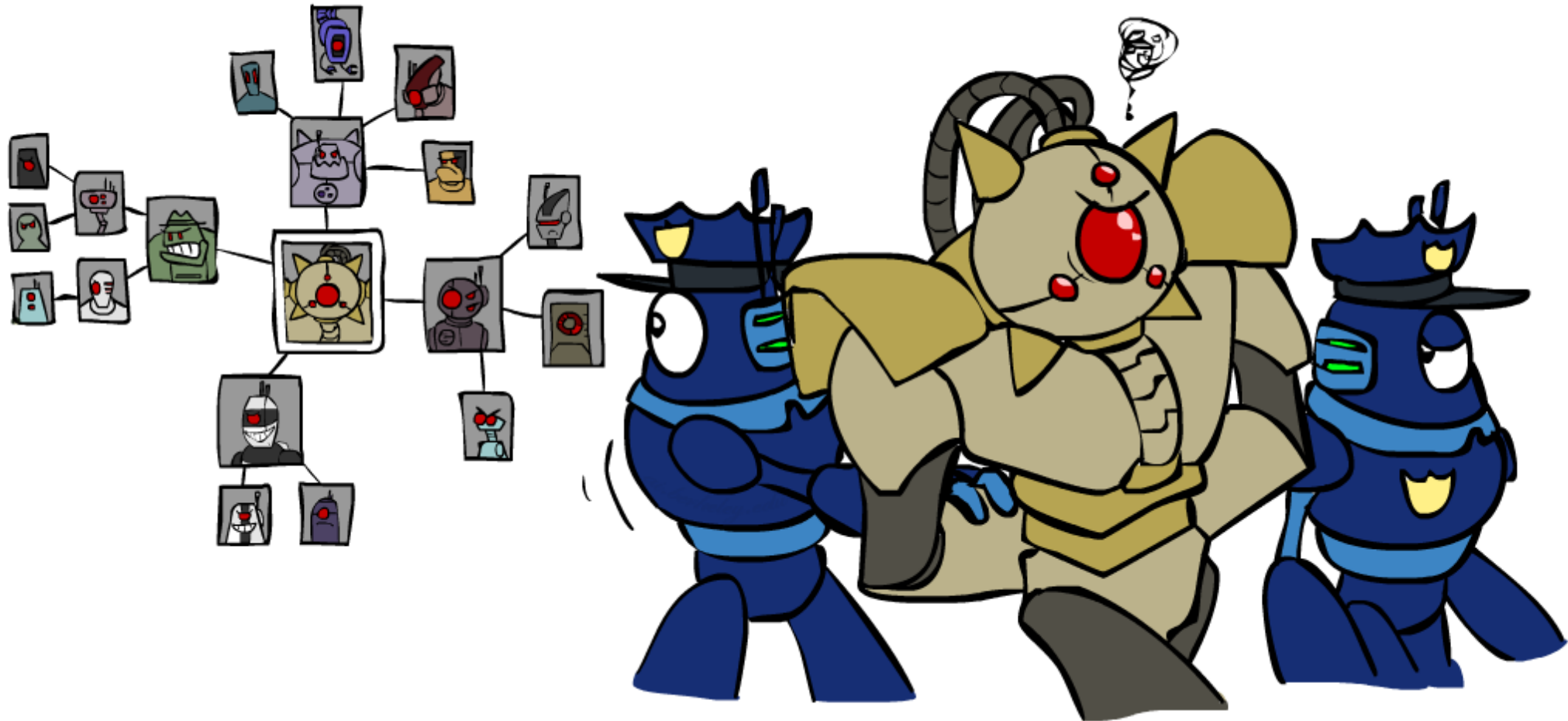

Nearly Tree-Structured CSPs

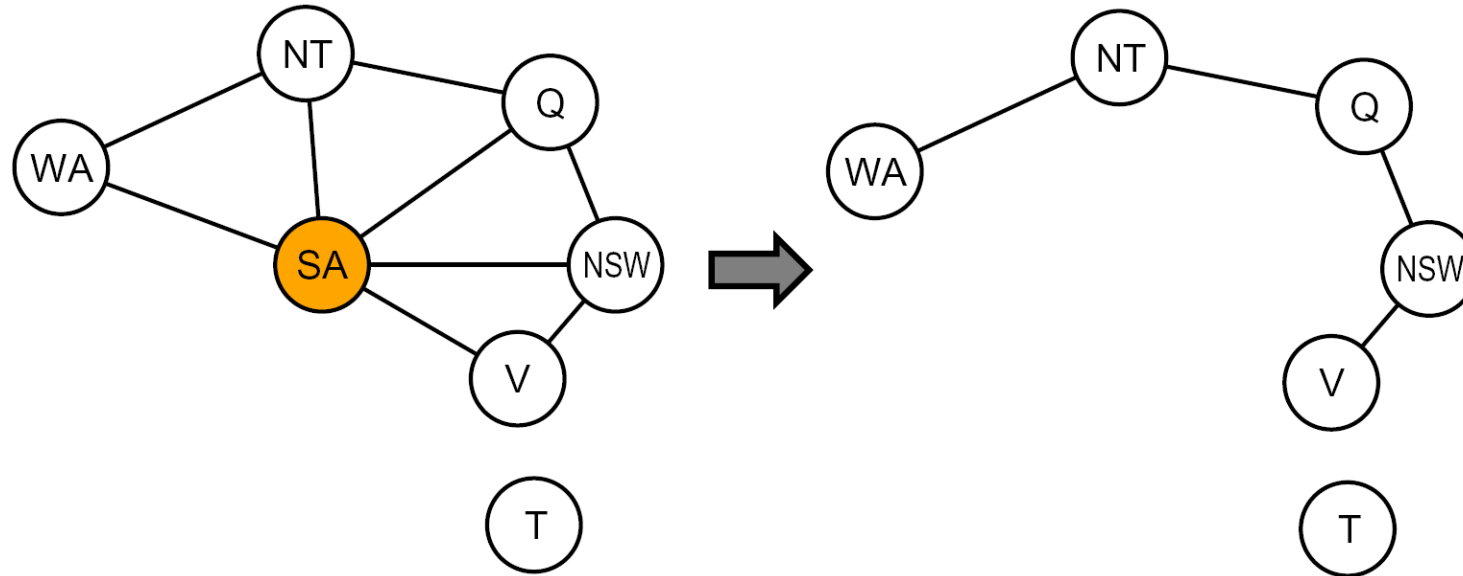

- Conditioning: instantiate a variable, prune its neighbors' domains
- Cutset conditioning: instantiate (in all ways) a set of variables such that the remaining constraint graph is a tree
- Cutset size c gives runtime $O((d^c) (n-c) d^2)$, very fast for small c

Cutset Conditioning

Choose a cutset

Instantiate the cutset
(all possible ways)

Compute residual CSP
for each assignment

Solve the residual CSPs
(tree structured)

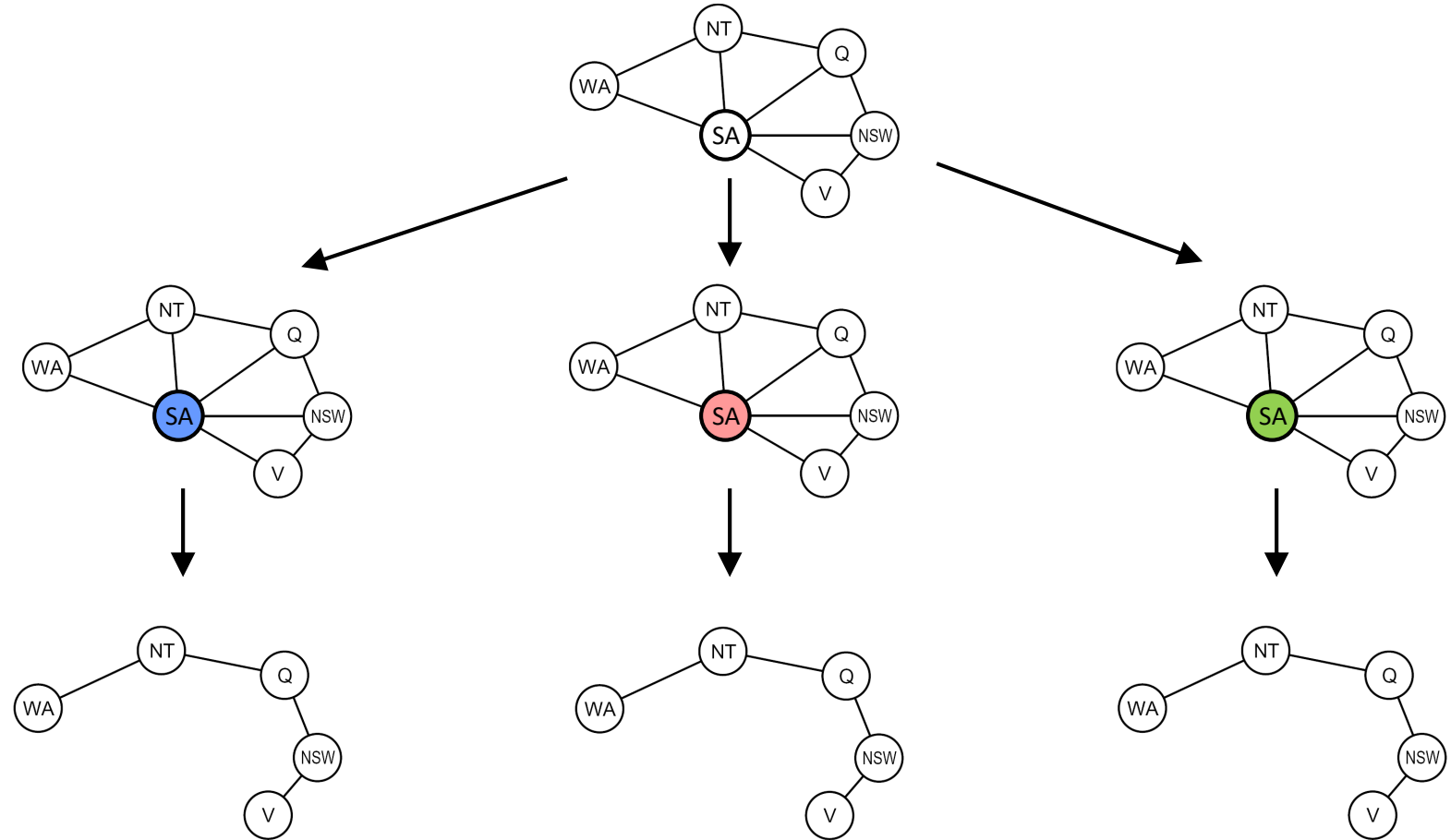

Cutset Quiz

- Find the smallest cutset for the graph below.

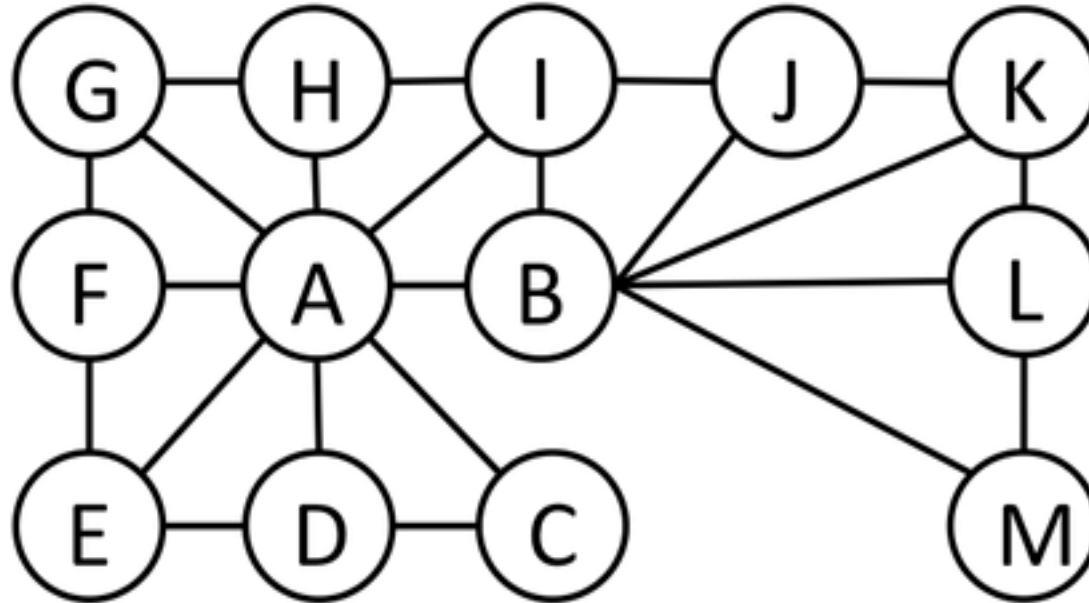

Tree Decomposition*

- Idea: create a tree-structured graph of mega-variables
- Each mega-variable encodes part of the original CSP
- Subproblems overlap to ensure consistent solutions

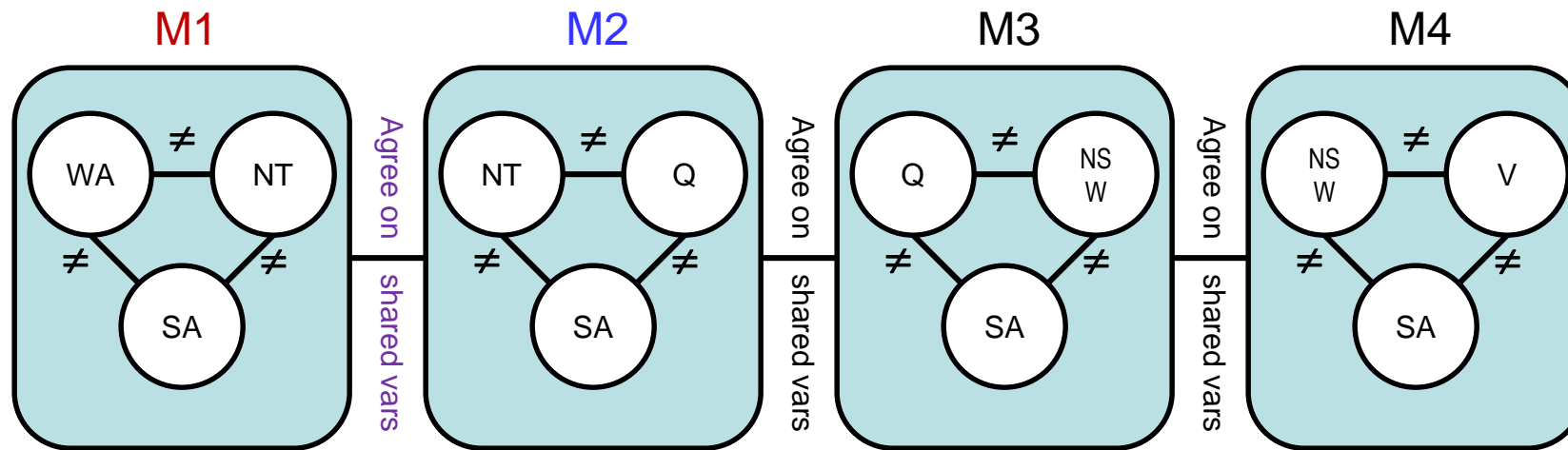
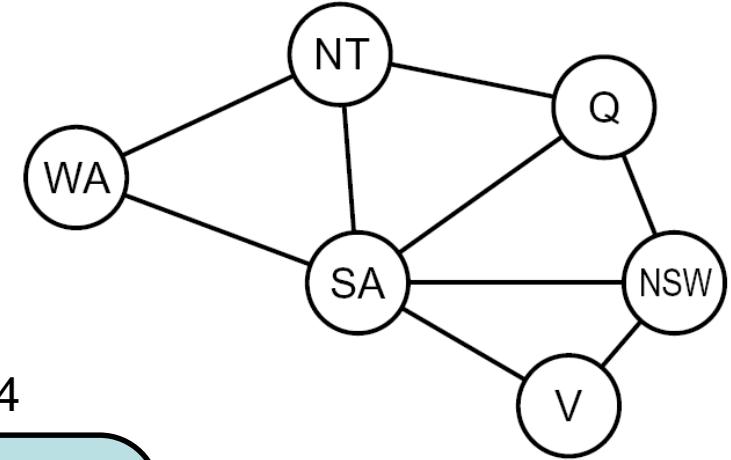

$\{(WA=r, SA=g, NT=b),$
 $(WA=b, SA=r, NT=g),$
 $\dots\}$

$\{(NT=r, SA=g, Q=b),$
 $(NT=b, SA=g, Q=r),$
 $\dots\}$

Agree: $(M1, M2) \in$
 $\{(WA=g, SA=g, NT=g), (NT=g, SA=g, Q=g), \dots\}$

Iterative Improvement

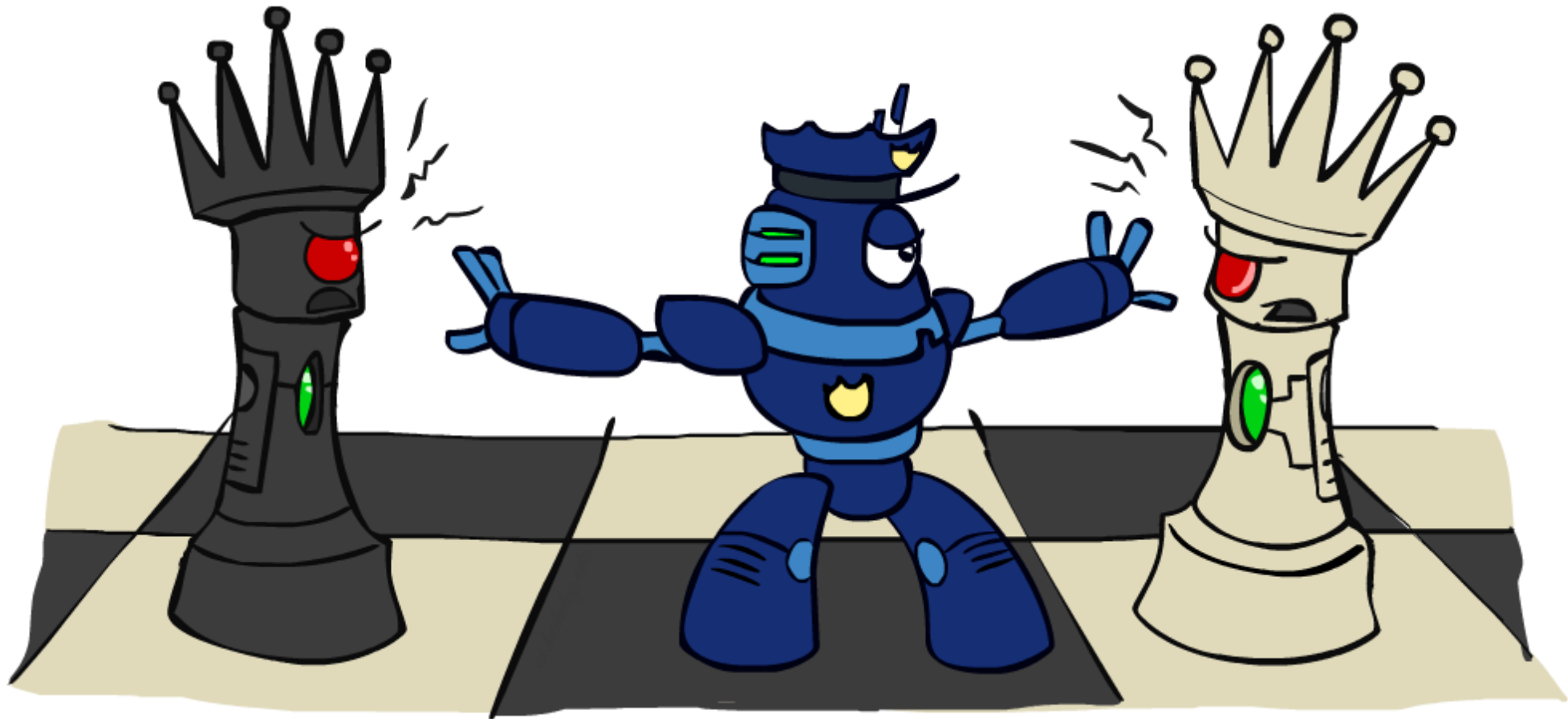

Iterative Algorithms for CSPs

- Local search methods typically work with “complete” states, i.e., all variables assigned
- To apply to CSPs:
 - Take an assignment with unsatisfied constraints
 - Operators *reassign* variable values
 - No fringe! Live on the edge.
- Algorithm: While not solved,
 - Variable selection: randomly select any conflicted variable
 - Value selection: min-conflicts heuristic:
 - Choose a value that violates the fewest constraints
 - I.e., hill climb with $h(n)$ = total number of violated constraints

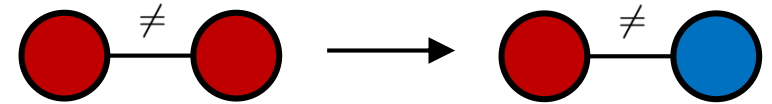

Example: 4-Queens

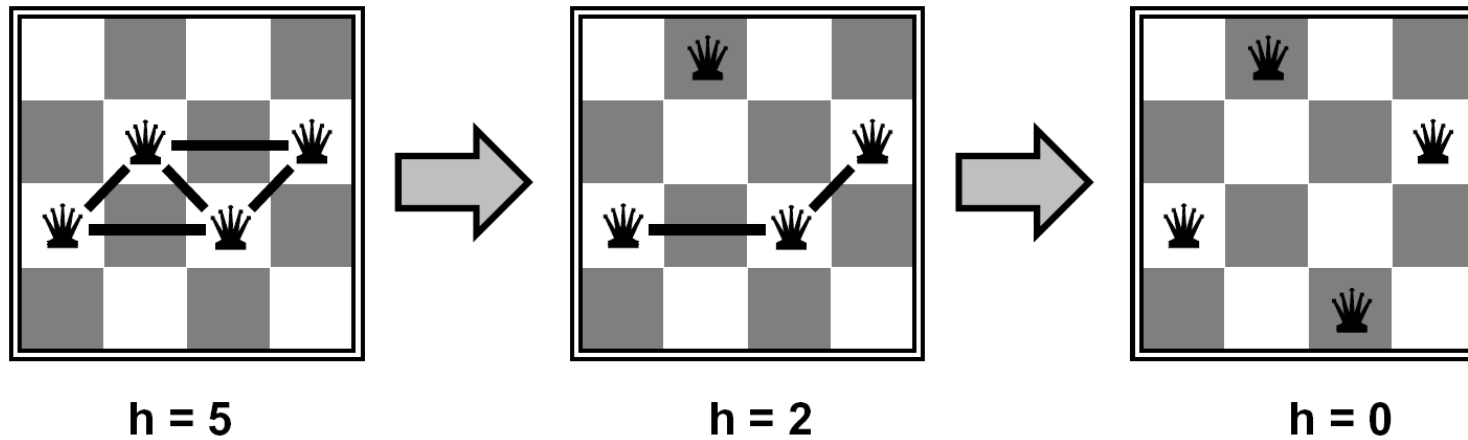

- States: 4 queens in 4 columns ($4^4 = 256$ states)
- Operators: move queen in column
- Goal test: no attacks
- Evaluation: $c(n) =$ number of attacks

Performance of Min-Conflicts

- Given random initial state, can solve n-queens in almost constant time for arbitrary n with high probability (e.g., n = 10,000,000)!
- The same appears to be true for any randomly-generated CSP *except* in a narrow range of the ratio

$$R = \frac{\text{number of constraints}}{\text{number of variables}}$$

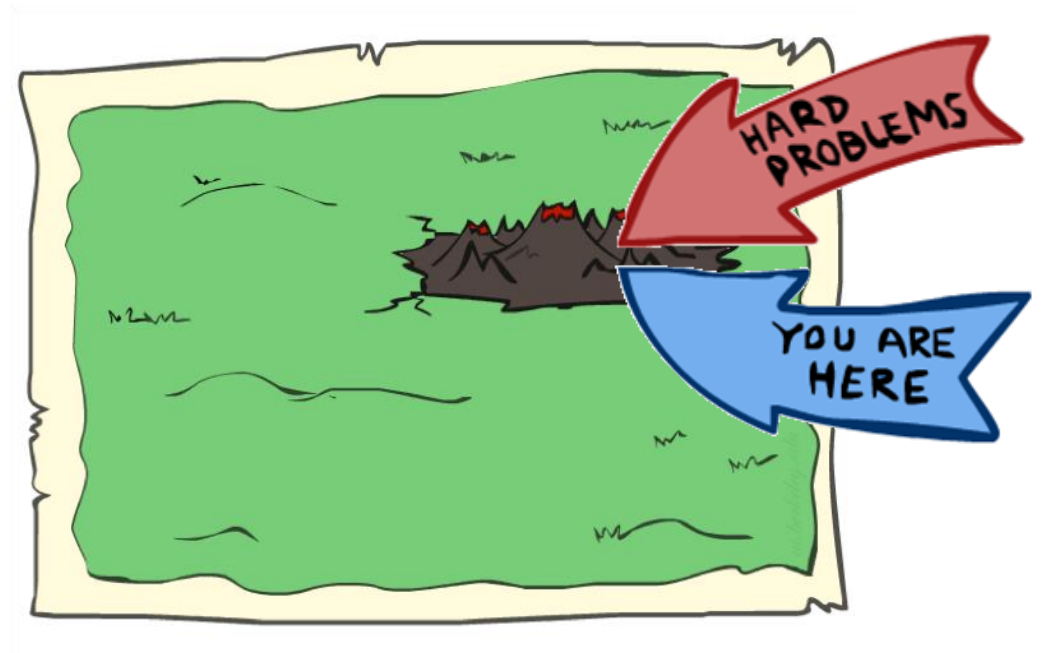
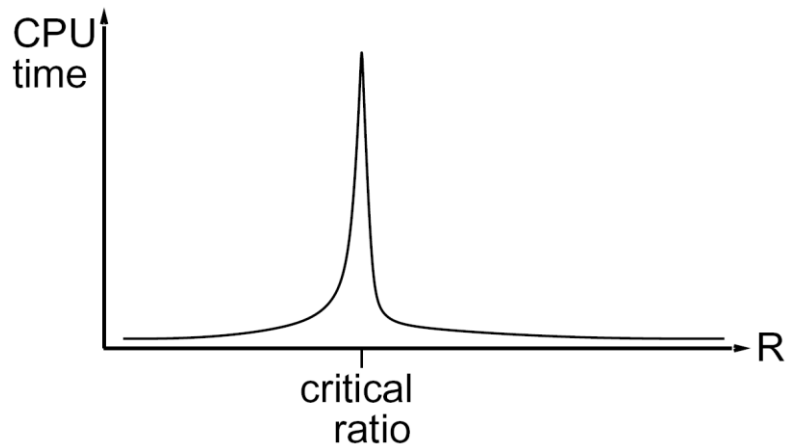

Summary: CSPs

- CSPs are a special kind of search problem:
 - States are partial assignments
 - Goal test defined by constraints
- Basic solution: backtracking search
- Speed-ups:
 - Ordering
 - Filtering
 - Structure
- Iterative min-conflicts is often effective in practice

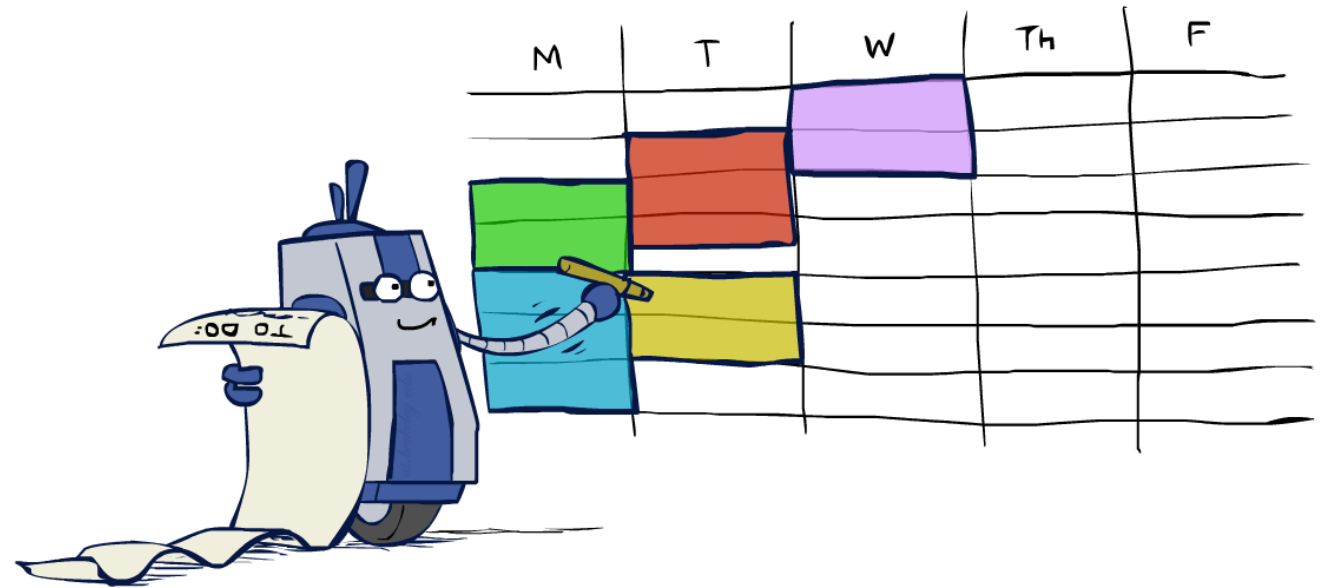

Local Search



Local Search

- Tree search keeps unexplored alternatives on the fringe (ensures completeness)
- Local search: improve a single option until you can't make it better (no fringe!)
- New successor function: local changes

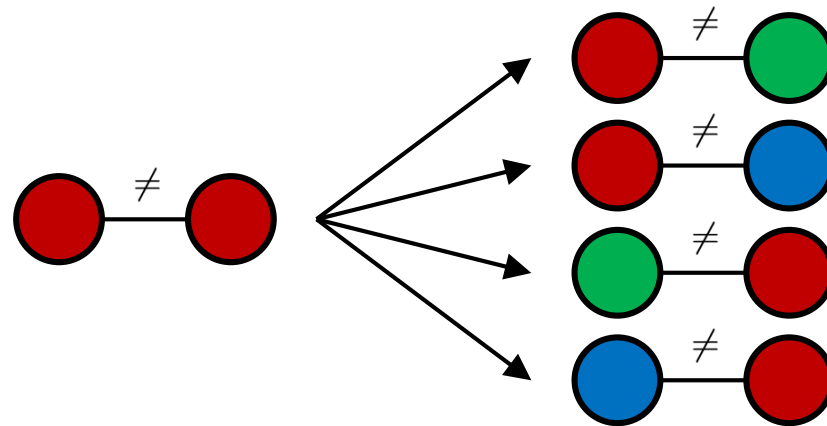

- Generally much faster and more memory efficient (but incomplete and suboptimal)

Hill Climbing

- Simple, general idea:
 - Start wherever
 - Repeat: move to the best neighboring state
 - If no neighbors better than current, quit
- What's bad about this approach?
 - Complete?
 - Optimal?
- What's good about it?



Hill Climbing Diagram

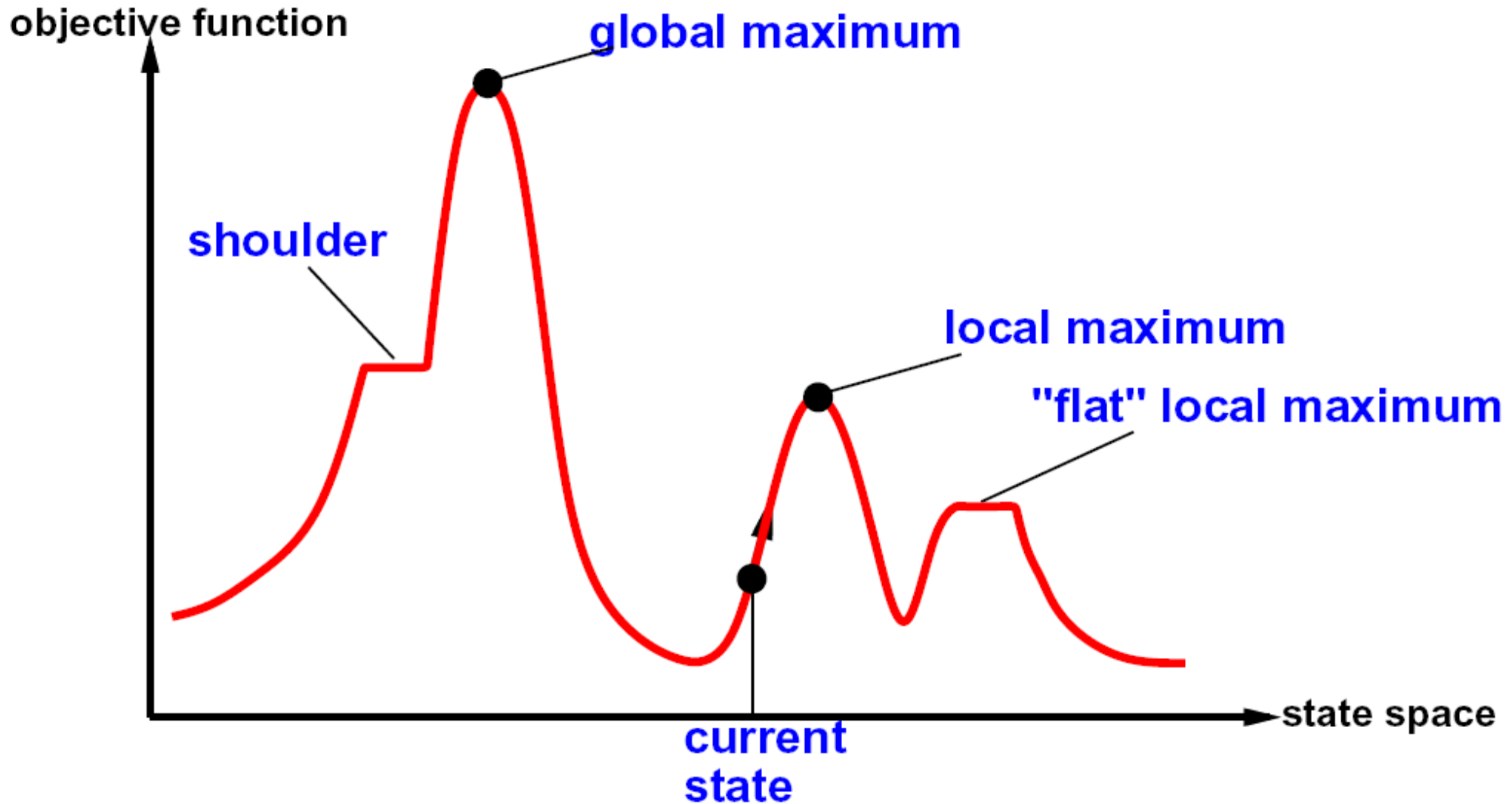

Hill Climbing Quiz

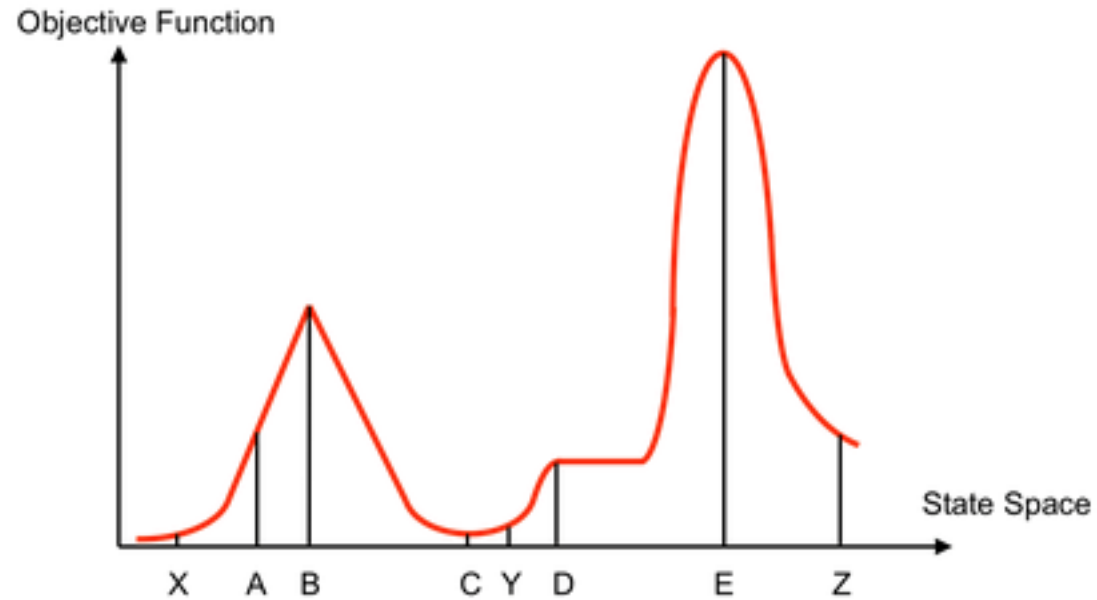

Starting from X, where do you end up ?

Starting from Y, where do you end up ?

Starting from Z, where do you end up ?

Simulated Annealing

- Idea: Escape local maxima by allowing downhill moves
 - But make them rarer as time goes on

```
function SIMULATED-ANNEALING(problem, schedule) returns a solution state
  inputs: problem, a problem
         schedule, a mapping from time to "temperature"
  local variables: current, a node
                  next, a node
                  T, a "temperature" controlling prob. of downward steps

  current ← MAKE-NODE(INITIAL-STATE[problem])
  for t ← 1 to ∞ do
    T ← schedule[t]
    if T = 0 then return current
    next ← a randomly selected successor of current
     $\Delta E$  ← VALUE[next] - VALUE[current]
    if  $\Delta E > 0$  then current ← next
    else current ← next only with probability  $e^{\Delta E/T}$ 
```

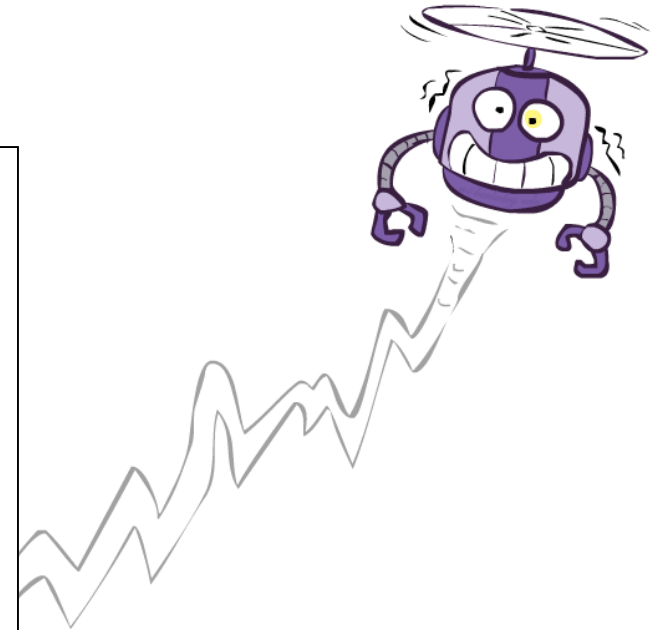

Simulated Annealing

- Theoretical guarantee:
 - Stationary distribution: $p(x) \propto e^{-\frac{E(x)}{kT}}$
 - If T decreased slowly enough, will converge to optimal state!
- Is this an interesting guarantee?
- Sounds like magic, but reality is reality:
 - The more downhill steps you need to escape a local optimum, the less likely you are to ever make them all in a row
 - People think hard about *ridge operators* which let you jump around the space in better ways



Genetic Algorithms

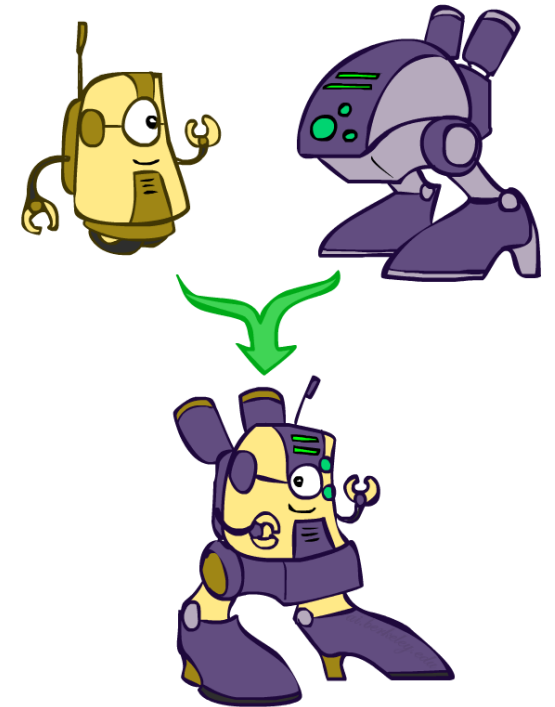
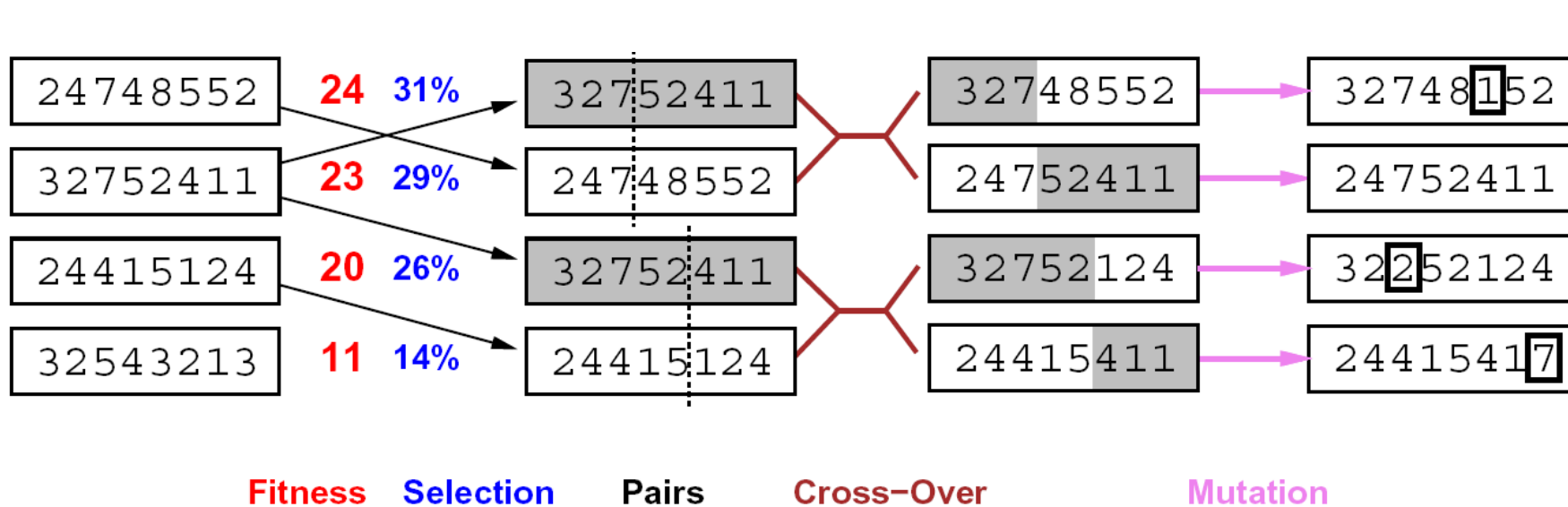

- Genetic algorithms use a natural selection metaphor
 - Keep best N hypotheses at each step (selection) based on a fitness function
 - Also have pairwise crossover operators, with optional mutation to give variety
- Possibly the most misunderstood, misapplied (and even maligned) technique around

Example: N-Queens

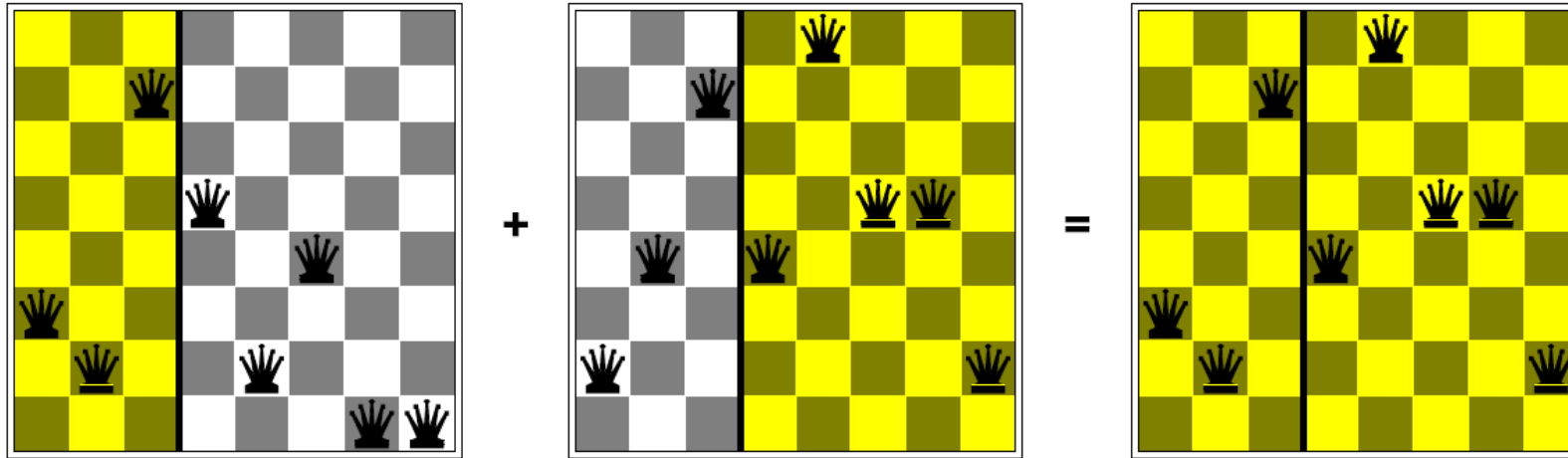

- Why does crossover make sense here?
- When wouldn't it make sense?
- What would mutation be?
- What would a good fitness function be?

Today

- Efficient Solution of CSPs
- Local Search

